



**THE SPECIALIST FOR
3D PRINTING WITH
POLYPROPYLENE**

Unique product portfolio

Our innovative product portfolio includes everything you need for seamless and high-quality 3D printing of polypropylene: PP materials in different colors, an optimized 3D printing surface, a support material and other accessories for 3D printing with PP.

3D printing know-how and material expertise

Design & Construction

Implement your 3D designs and parts with our help according to your ideas. With our experience and capabilities, we support you in designing sophisticated polypropylene parts for additive manufacturing.

Printing service

Our printing service team optimizes your products to the highest level of perfection with our expertise and manufactures PP parts for you using extrusion-based 3D printing. In addition, we offer surface finishing of 3D printed PP parts.

Trainings

Our professional team offers you individual technical support, consulting and training. This opens up the possibility of an easy and efficient entry into extrusion-based 3D printing and a professional production of PP parts.

OUR MISSION: ESTABLISHING PP IN 3D PRINTING.



Customer focus

At PPprint, the primary focus is on the success of our customers in their 3D printing applications with PP. We guarantee this through flexible and application oriented customer support.



Specialization

The exclusive focus on the material PP in 3D printing, allows us to apply our many years of experience and pass it on to our customers.



Expertise

The interdisciplinary and research-oriented PPprint team possesses diverse expertise and know-how in a wide range of areas, making it a perfect one-stop shop for questions about 3D printing with PP.



MEDICAL TECHNOLOGY

The excellent chemical and mechanical properties of our PP materials also speak for the applications in medical technology.

show certificate



3D printed parts made of P-filament 721 natural have the biological compatibility certification according to DIN EN ISO 10993-5 and P-filament 721 natural is thus suitable for direct skin contact when used as, e.g., orthoses and prostheses.

AUTOMOTIVE INDUSTRY

PP is already widely used in the automotive industry, which naturally makes it very interesting as a 3D printing material. The range of applications includes tools, working prototypes, and small series parts.



certified biological safety

3D printed parts made from **P-filament 721** natural are certified as biologically compatible.



lightweight

Due to its low density, polypropylene is suitable for 3D printing of light-weight components.



chemical resistant

Due to its chemical nature, polypropylene is very stable when exposed to most chemicals and solvents.



recyclable

Established processes for recycling are available for thermoplastic polypropylene.



break resistant

3D printed parts made of polypropylene are very robust and have a high break resistance.



semi-flexible

3D-printed parts made of PP can be bent to a certain degree without breaking.



lightweight

Due to its low density, polypropylene is suitable for 3D printing of light-weight components.



break resistant

3D printed parts made of polypropylene are very robust and have a high break resistance.



sterilizable

3D-printed parts made of PP can be sterilized by various methods.



appealing surface quality

The extrusion-based 3D printing of PP creates visually and haptically appealing surfaces.



homogeneously colorable

PP can be homogeneously colored over the entire color range using specially developed pigments.



no absorption of water

Due to its chemical nature, PP does not absorb water and there is no need for pre-treatment before 3D printing.

ART, DESIGN, CONSUMER GOODS



Particularly in the end customer segment, the versatile property profile of PP offers enormous potential for a wide variety of applications. In this area, our optimized PP materials also open up the possibility of successful 3D printing of individualized products.

TOOLMAKING & MOLDS



The use of additive manufacturing in tool and mold making offers the possibility to operate flexibly and in a resource-saving manner. With polypropylene, individual industrially applicable molds, tools and components can be produced using 3D printing.



food safe

The raw material polypropylene used does not contain plasticizers and is classified as food safe.



dishwasher safe

Polypropylene can be easily cleaned in different ways and is dishwasher safe.



break resistant

3D printed parts made of polypropylene are very robust and have a high break resistance.



homogeneously colorable

PP can be homogeneously colored over the entire color range using specially developed pigments.



recyclable

Established processes for recycling are available for thermoplastic polypropylene.



withstands up to 100 °C

3D-printed parts made of PP can be exposed to temperatures of up to 100 °C for short periods.



break resistant

3D printed parts made of polypropylene are very robust and have a high break resistance.



recyclable

Established processes for recycling are available for thermoplastic polypropylene.



semi-flexible

3D-printed parts made of PP can be bent to a certain degree without breaking.



chemical resistant

Due to its chemical nature, polypropylene is very stable when exposed to most chemicals and solvents.



lightweight

Due to its low density, polypropylene is suitable for 3D printing of lightweight components.



homogeneously colorable

PP can be homogeneously colored over the entire color range using specially developed pigments.

ONE-STOP-SHOP POLYPROPYLENE 3D PRINTING.

Filaments

Our polypropylene created specifically for Fused Filament Fabrication (FFF) when processed to **P-filament 721** provides easy and high-quality 3D printing.

Pellets

Our **P-pellets 310** developed specially for Fused Granular Fabrication (FGF) enable smooth and reliable 3D printing with PP pellets.

Support material

The world's first 'break-away' support material specifically developed for PP, **P-support 279**, enables the manufacturing of complex geometries.

3D printing build surface

Our patent-pending **P-surface 141** 3D printing build surface ensures reliable adhesion of the PP parts during 3D printing and is sustainable because it is very robust and can be used repeatedly.

Accessories and Kits

Our **PPprint Printing Kits** and accessories ensure an optimal start for the successful production of 3D printed products with PP.



Immediately 3D printable

Since our PP materials are not water-absorbent, they can be used immediately without further pretreatment and drying or can be reused after a longer interruption.



Suitable for any 3D printer

Our complete product portfolio is aligned in a way that all PPprint products can be used in almost any FFF 3D printer and enable 3D printing with PP.



Samples and Kits

Our free test materials, as well as our PPprint Starter Kit, make it easy and straightforward to get started with polypropylene 3D printing.

POLYPROPYLENE FILAMENT FROM THE SPECIALIST.

The polypropylene (PP) filament, **P-filament 721**, combines low warpage and shrinkage with extremely high interlayer bonding and can be printed with almost all common FFF 3D printers.



break resistant



semi-flexible



light weight



chemical resistant



recyclable



no absorption of water



homogeneously
colorable



immediately
3D printable



breakaway
support material



appealing
surface quality



certified
biological safety



sterilizable



food safe



dishwasher safe



withstands up to 100 °C

Neutral filaments



natural



white



black

Colored filaments



orange

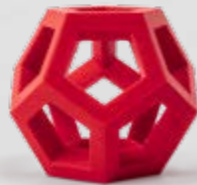

red



pink



purple



yellow



green

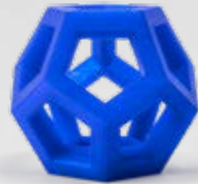

blue



signal-blue



beige



grey



Customizable sizes, diameters and colors.

Are you interested in other spool sizes, filament diameters or color variants? We also produce individual product variants for your specific applications on request. Please contact us directly via office@ppprint.de.



Designed for easy handling and excellent results.

Our mission is to establish the material PP worldwide in extrusion-based 3D printing. For this reason, all our products are designed to be easy to install and use, while delivering outstanding results.

Available sizes and diameters

Neutral filaments	Sizes	0.6 kg, 1.8 kg
	Diameter	1.75 mm, 2.85 mm
Neutral filaments	Sizes	0.6 kg
	Diameter	1.75 mm, 2.85 mm

Individual solutions on request: office@ppprint.de

Recommended printing parameters

3D printing surface	<i>P-surface 141</i>	
Extruder temperature	200-220 °C	
Printing bed temperature	During the first layer	70-80 °C
	During 3D printing	20 °C
	After finishing the print job	100-110 °C
Heated 3D printing chamber	Tempering not necessary.	

P-filament 721 Certificates & Data Sheets:
On our website you will find further information and downloads about our products.



PP for extrusion-based 3D printing with pellets

Since larger nozzle diameters are commonly used in 3D printing with pellets, the flow behavior of the PP material must be suitable for this. Precisely for this purpose, the **P-pellets 310** were developed and optimized.

Available from an order quantity of just 1 kg

As PPprint GmbH is a customer-oriented firm, we also provide lower pellet quantities so that all clients can experience the benefits of **P-pellets 310**.

Usable without pretreatment

Just as in the case of using **P-filament 721**, **P-pellets 310** are not water absorbent due to the chemical structure of PP and can therefore be used directly without pretreatment and even after longer interruptions.

Easy handling

The direct use of pellets eliminates the need for costly filament production, and the uniform pellet size of the **P-pellets 310** guarantees successful 3D printing.

HIGH-QUALITY POLYPROPYLENE PELLETS.

The polypropylene pellets, **P-pellets 310**, were specially developed for extrusion-based 3D printing and have excellent 3D printing properties. **P-pellets 310** offer extremely high inter-layer bonding, as well as low warpage and shrinkage.



P-pellets 310 Certificates & Data Sheets:
On our website you will find further information
and downloads about our products.



Developed for 3D printing with PP

The worldwide unique support material, **P-support 279**, has been specially adapted to PP material through years of research and enables 3D printing of complex geometries with overhangs, openings and bridges. **P-support 279** has very low warpage, is very stiff and adheres extremely strongly to the PP component during 3D printing. This combination of properties leads to a strong compensation of the warpage of the PP printed part.

100% recyclable

Our 'break-away' **P-support 279** is designed to be fully recyclable. It can be collected by type after removal, and due to its thermoplastic properties, it can be remelted and reprocessed into as-new **P-support 279** filament. With our Circular Economy process, we have created the perfect framework for our customers to combine sustainability and money saving. For more information, see [page 19](#).

Easy and clean removal

During 3D printing, our **P-support 279** adheres extremely strongly to the 3D-printed PP component and thus prevents warpage. After 3D printing, it can be easily removed from the component without leaving any residue after heating to 100 °C – 110 °C in the hot state due to its then chewing gum-like properties. In general, no further post-treatment step is necessary.



THE IDEAL SUPPORT MATERIAL FOR PP PRINTING.

P-support 279 is the first 'break-away' support material developed specifically for polypropylene, allowing even more detailed and complex structures to be realized.

P-support 279 is available in diameters of 1.75 mm and 2.85 mm and can be printed on almost all 3D printers.



P-support 279 Certificates & Data Sheets:
On our website you will find further information and downloads about our products.



WE RECYCLE YOUR PP-SUPPORT-MATERIAL.



- 1 Request a free **return label**.
- 2 Return printed **P-support 279** structures.
- 3 Receive a **discount** on your next **P-support 279** order.
- 4 Print cheaper and **protect the environment**.



10% discount

For every 500 g of **P-support 279** returned, PPprint will grant a 10% discount on the next 600 g **P-support 279** spool order. The discount will be granted only for the return of clean and sorted material.



Free return shipping

PPprint provides the return label for your sorted collected **P-support 279**. In Europe, as a PPprint recycling partner, you will not incur any extra costs regarding return shipping.



Tested material quality

Even if you return the **P-support 279** as a PPprint recycling partner, you will always receive the original **P-support 279**. The recycled **P-support 279** will be sold under a different name in the future.

Developed for 3D printing with PP

Our **P-surface 141** is the solution to adhesion problems that arise while 3D printing with PP on the printer's bed. **P-surface 141** is very robust and can be reused as often as desired with the appropriate cleaning and care using **P-surface cleaner 298**. This is a very sustainable solution because other thermoplastics like PLA, ABS or PC can also be printed on it.

Individual sizes for every 3D printer

The rubber-like properties of the innovative **P-surface 141** 3D printing build surface allow individual production in the sizes of all common 3D printers. Greater sizes, such as 1 m x 1 m or even larger, can be produced on demand.

Uncomplicated handling

P-surface 141 impresses with its sustainable and uncomplicated handling. Due to its self-adhesive properties on very smooth surfaces, such as glass, it can be applied there directly without adhesives. For rough surfaces, bonding with the double-sided adhesive film **P-adhesive 220** is recommended.

Suitable Cleaning-Kit available

The **PPprint Cleaning-Kit** is ideal for cleaning and maintaining the **P-surface 141**. Using the **P-surface cleaner 298** and after final cleaning with the **P-wipe 515**, almost any residue or dirt is effortlessly removed and at the same time the **P-surface 141** can be well maintained.

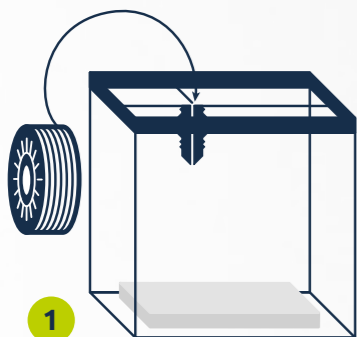
1

Place **P-filament 721** into your 3D printer. For complex geometries, you have to use **P-support 279**. It is not required to dry both filaments prior to use

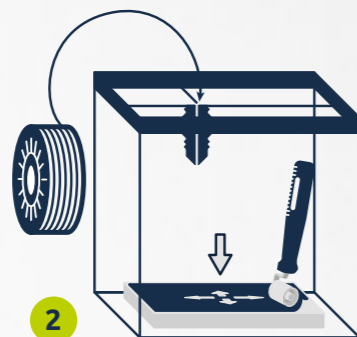
2

Place **P-surface 141** with the PPprint logo facing upwards on your printer bed and fix it with gentle pressure using the **P-roller 621**. You have also the option to adhere **P-surface 141** to your printer bed by using **P-adhesive 220**.

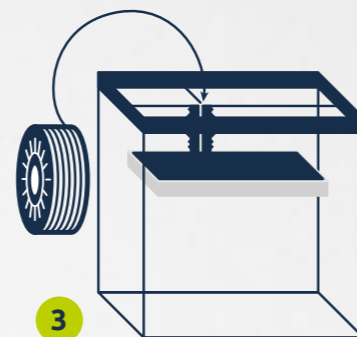
3

Heat up the extruder temperature to **210 °C**, recalibrate your printing platform and start printing. To remove the finished part without destruction, the printer bed has to be heated to **110 °C**.

THE PERFECT PRINTING BED FOR POLYPROPYLENE.

The **P-surface 141** 3D printing build surface ensures ideal adhesion of our **P-filament 721** during printing and at the same time enables easy removal of the printed parts after completion at elevated print bed temperatures.



P-surface 141 Certificates & Data Sheets:
On our website you will find further information and downloads about our products.



Specific accessories for every 3D printer.

Depending on the specification of your 3D printer, we offer you everything for successful 3D printing with the material PP. Our accessories are developed in the way that they are suitable for all 3D printers or can be adapted to them in terms of size and shape.



P-wipe 515 and P-surface cleaner 298 available as a Kit!

The **PPprint Cleaning-Kit** consists of the **P-wipe 515** and the **P-surface cleaner 298** and contains everything that you need to clean and maintain the **P-surface 141**. The professional and regular use of the Cleaning-Kit also has a positive effect on the service life of the **P-surface 141**.

ACCESSORIES FOR AN IDEAL PRINTING RESULT.

The **PPprint accessories** support you in the most diverse challenges of 3D printing with PP. As a result, the accessories facilitate PPprint product installation as well as trouble-free and successful 3D printing with the PP material.

1 P-surface cleaner 298*

The **P-surface cleaner 298** is used to clean and maintain the **P-surface 141**. The **P-surface cleaner 298** is biodegradable and available in the sizes 10 ml and 250 ml.

2 P-adhesive 220

Since the self-adhesive property of **P-surface 141** is not strong on rough surfaces, the double-sided adhesive film **P-adhesive 220** was specially developed for fixing **P-surface 141** to these surfaces.

3 P-wipe 515

P-wipe 515 is ideal for final wet cleaning of **P-surface 141** after pre-cleaning with **P-surface cleaner 298**. It is highly absorbent and durable and has a long service life.

4 P-scraper 458

The **P-scraper 458** is an ideal aid for bubble-free application of the double-sided adhesive film **P-adhesive 220**. Particularly with large-area **P-adhesive 220**, application is quick and effortless.

5 P-roller 621

The **P-roller 621** is the ideal tool for applying the **P-surface 141** 3D printing surface. With the **P-roller 621**, the **P-surface 141** can be installed easily with uniform pressure.

6 Glass plate

A customized glass plate, suitable for your printer, allows **P-surface 141** to be installed directly onto this flat glass surface. Utilizing the self-adhesive property of **P-surface 141** on smooth surfaces also allows repeatable removal and reinstallation of the 3D printing build surface.



* Safety Data Sheet
P-surface cleaner 298



Accessoires Certificates & Data Sheets:
On our website you will find further information
and downloads about our products.



PPprint Test-Kit

The **PPprint Test-Kit** offers you the possibility to test our material free of charge and in the most uncomplicated way. The test kit consists of a sample of the **P-filament 721**, a test size of the 3D printing build surface **P-surface 141** and the double-sided adhesive film **P-adhesive 220**.



PPprint Starter-Kit

The **PPprint Starter Kit** consists of a 600g spool of **P-filament 721** (1.75 mm or 2.85 mm), the 3D printing build surface **P-surface 141** (200 mm x 230 mm), the double-sided adhesive film **P-adhesive 220** (200 mm x 230 mm) and the **P-roller 621** to apply the 3D printing build surface.



PPprint Kits individual

The **PPprint Printing Kits** enable simple, reliable and reproducible 3D printing with polypropylene on your 3D printer. The individual printing kit can be adapted to the dimensions of your 3D printer, and consists of the corresponding 3D printing build surface **P-surface 141**, the double-sided adhesive film **P-adhesive 220**, the **P-roller 621**, the **P-wipe 515** and a sample **P-surface cleaner 298**.

Easily upgrade your 3D printer to print with PP material.

The PPprint products and kits are designed to guarantee an easy installation and to enable 3D printing with PP in highest quality. For this reason, all PPprint products are designed for easy installation and can be used in your FDM 3D printer.

Professional setup of your 3D printer for printing with PP.

Are you interested in having your 3D printer set up by a PPprint expert? Feel free to contact us for our individual training packages for getting started with 3D printing with PP. Thereby, we offer training in virtual as well as in physical form.

EASY START WITH THE PPprint KITS.

The **PPprint Test-Kit** and the PPprint Starter-Kit offer you the possibility to test our product portfolio and to get into 3D printing with PP in an easy way. Furthermore, with the customizable **PPprint Printing Kits**, you have the possibility to upgrade your 3D printer to an optimally equipped PP 3D printer.



Glass plate available as accessory, see page 23.

RESEARCH, DEVELOPMENT, INNOVATION.

2018

Gründung

PPprint GmbH is founded as a spin-off from the University of Bayreuth with headquarters in Bayreuth. The founders have many years of experience in polymer research, materials development, industrial engineering and business administration.

2019

Market launch of filaments and 3D printing build surface

Introduction of the **P-filament 721** product range in the diameters 1.75 mm and 2.85 mm. Establishment of the production of the 3D printing build surface **P-surface 141** for common sizes of many FFF 3D printers. Introduction of the **PPprint Starter Kit** for an easy and successful start into 3D printing with PP.

2020

Market launch of colored filaments and support material

Introduction of **P-filament 721** in black, white and other colors. Following successful research and development results, the support material **P-support 279** was introduced to the market. This world's first 'break-away' support material enables 3D printing of complex products made of PP.

2021

Development of a surface flattening process

As part of development work, a solvent-based process for surface flattening was set up. We offer this service on customer request on 3D printed PP components.



PP printing with post-processed surface

PP printing with untreated surface



Active research and development

We are researching optimized PP materials to expand our product portfolio focused on applications in various industrial fields.



Continuous improvement

We are constantly working on the further development of our materials, e. g. with regard to the further reduction of warpage and shrinkage of 3D-printed parts.



Sustainability

The avoidance of waste is also becoming increasingly important in the field of additive manufacturing. That is why we are working on concepts to establish a circular economy with our materials.



KNOW-HOW OUT OF FIRST HAND: PPprint **SUPPORT.**



Close customer relationship

As a small and PP-focused company, we maintain an intensive, fast and competent exchange with our customers.



Online support

We offer our customers the possibility of an uncomplicated virtual support. This service is highly appreciated by our customers.



Workshops

Our workshops provide the basics of extrusion-based 3D printing with PP, introduction and training with a selected slicer software and hands-on training on a selected 3D printer.



Free Test-Kit

You would like to experience the quality of our products? Request the free **PPprint Test-Kit** now.



EASILY START 3D PRINTING WITH PPprint.



PPprint Starter-Kit

The **PPprint Starter Kit** offers you the perfect opportunity to test 3D printing of polypropylene intensively on your 3D printer.



Become a reseller



Are you interested in becoming a reseller or cooperation partner? Contact us with your request and we will get back to you promptly:
office@ppprint.de

Subscribe to newsletter



Would you like to receive the latest news about us and our product portfolio? Register now for our newsletter:
ppprint.de/newsletter





PPprint GmbH
Gottlieb-Keim-Straße 60
D-95448 Bayreuth
www.ppprint.de